



Non-invasive CLAMP-ON ultrasonic flowmeter for liquids

- Model CU100: non-invasive installation flowmeter, with transducers installed outside the pipe
- Installation in horizontal or vertical pipe
- Easy and inexpensive installation, without interruption in the manufacturing process
- No pressure drop
- No risk of leakage
- No maintenance required
- Allows flow measurement in high pressure processes
- Graphic display with intuitive menus
- Possibility of programming by means of PC and software Winsmeter CU
- Flow speed range: 0.2 ... 12 m/s
- Accuracy: $\pm 1.5\%$ reading value ± 0.02 m/s
- Connections: external mounting in pipes of diameter between DN80 ... DN2000. Optional installation by means of guide or transducer straps
- Materials:
 - Transducers: Anodized aluminium
 - Electronic converter housing: ABS
 - Guide: Anodized aluminium
 - Transducer strap: EN 1.4301 (AISI 304)
- Electronic converter for remote mounting:
 - Power supply: 85 ... 265 VAC
 - Flow rate and speed indication
 - Programmable 4-20 mA output proportional to flow rate
 - Volume totalizer
 - 2 programmable relay outputs



Model CU100

Working principle

The flowmeter model CU100 is an electronic device based on the transmission of ultrasonic signals through a pipe where liquid flows. This working principle is called "transit time".

Two ultrasonic transducers, acting alternately as transmitter-receiver and properly installed on a pipe, send an ultrasonic signal, first in one direction (A→B), then in reverse (B→A).

A digital processor measures both transit times. When flow rate is zero, these times (A→B and B→A) are the same, but when there is a flow at a specific speed, the times for coming and going are different (A→B decreases, while B→A increases). The difference between these times is proportional to liquid speed inside the pipe.

An electronic circuit based on digital signal processing converts this difference in transit time into a flow rate value.

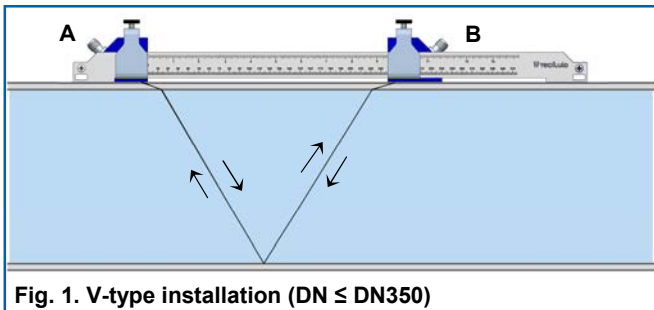

Fig. 1. V-type installation (DN ≤ DN350)

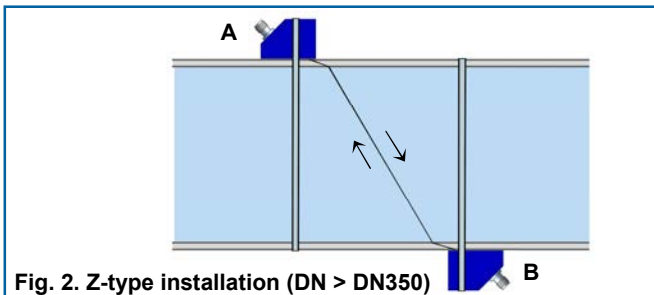

Fig. 2. Z-type installation (DN > DN350)

Applications

- Water treatment and distribution
- Food, pharmaceutical, chemical and paper industry
- Cooling-heating circuits
- Pools and irrigation systems
- Fire protection systems
- Automotive industry
- Power plants

Technical data

- Accuracy: $\pm 1.5\%$ reading value ± 0.02 m/s
- Repeatability: $\pm 0.25\%$ reading value ± 0.01 m/s
- Flow rate indication in metric or imperial units
- Flow speed range: 0.2 ... 12 m/s

- Liquid density and viscosity: no restrictions
- Liquid temperature: -20°C ... $+80^{\circ}\text{C}$
Others on request
- Ambient temperature: -20°C ... $+60^{\circ}\text{C}$
- Working pressure: no restrictions
- Connections: external mounting on pipe. Optional installation by means of guide or transducer straps. Suitable for pipe size between DN80 ... DN2000

Mechanical specifications

- Electronic converter:
 - Housing material: ABS
 - Dimensions: 229 x 203 x 62 mm
 - Ingress protection: IP65
 - Packing glands:
 - Power supply and outputs: 3 x M16x1.5 for cables with diameter between 3.5 and 10 mm
 - Transducers: 2 x PG7 for cables with diameter between 1.5 and 5 mm
 - Display: graphic, 128 x 64 points
 - Keyboard: 12 mechanical keys
 - Cable standard length 5 m for transducers-converter connection, supplied
Maximum cable length 50 m on request
- Transducers:
 - Material: Anodized aluminium
 - Dimensions: 60 x 25 x 44 mm
 - Ingress protection: IP65
- Installation system:
 - Materials:
 - Guide: Anodized aluminium
 - Dimensions: 500 x 41 x 65 mm
 - Transducer strap: EN 1.4301 (AISI 304)

Electrical specifications

- Power supply: 85 ... 265 VAC 50 / 60 Hz
- Power consumption: ≤ 5 VA
- Flow rate and speed indication:
 - n° of digits: 5 (up to 2 configurable decimals)
 - Size of digit: 11 mm
- Analog output: 4-20 mA, active or passive.
Power supply galvanically isolated
- Relay outputs: two change over contacts (SPDT).
 - Maximum voltage: 250 VAC
 - Maximum current: 8 A
 - Maximum power: 500 VA
- Totalizer:
 - n° of digits: 8 (2 decimals)
 - Size of digit: 8 mm
 - Reset: by means of keyboard
- Associated software Winsmeter CU available for download at www.tecfluid.com. USB connection for converter communication

Installation

For an accurate flow measurement, the ultrasonic flowmeter model CU100 requires a straight pipe run of minimum 5 x DN before and after the flowmeter. The required distance depends on the flow profile, which can be affected by the disturbing elements found in the installation before and after the transducers, as shown in the following chart:

Disturbing element	If the element is before the CU100	If the element is after the CU100
Pump	50 x DN	—
Tee	50 x DN	10 x DN
Valve	40 x DN	10 x DN
Diffuser	30 x DN	5 x DN
Reducer	10 x DN	5 x DN
90° elbow	10 x DN	5 x DN
2 x 90° elbow in one plane	25 x DN	5 x DN
2 x 90° elbow in different planes	40 x DN	5 x DN

In horizontal pipes, it is recommended to install the transducers on the sides of the pipe, and not on the upper and lower sides (Fig. 3), in order to avoid air accumulations or solids sediments that might interfere in flow reading.

The installation of the transducers can be done:

- Pipe DN80 ... DN350: by means of graduated guide and guide straps, supplied by Tecfluid (Fig. 4), V-type installation. Optional mounting by means of transducer straps (Fig. 5).

- Pipe DN400 ... DN2000: by means of transducer straps, supplied by Tecfluid (Fig. 5), Z-type installation. For these pipe sizes, the transducers must be installed opposite each other and the guide is not available.

Once the installation parameters have been programmed (pipe material, diameter and thickness, working liquid,...), the converter calculates the distance that must be kept between both transducers.

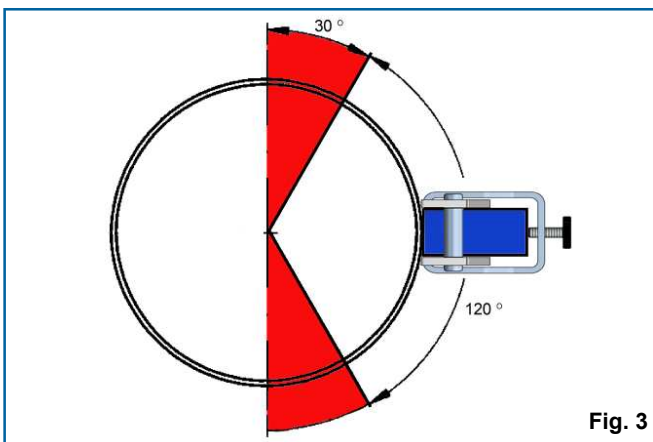

Fig. 3

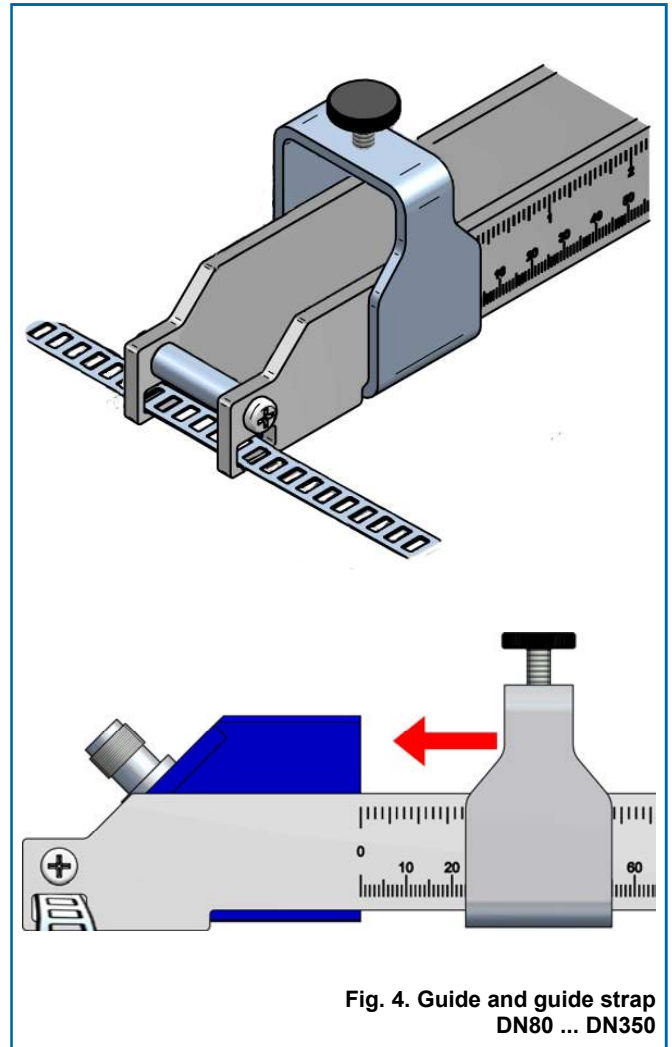

Fig. 4. Guide and guide strap DN80 ... DN350

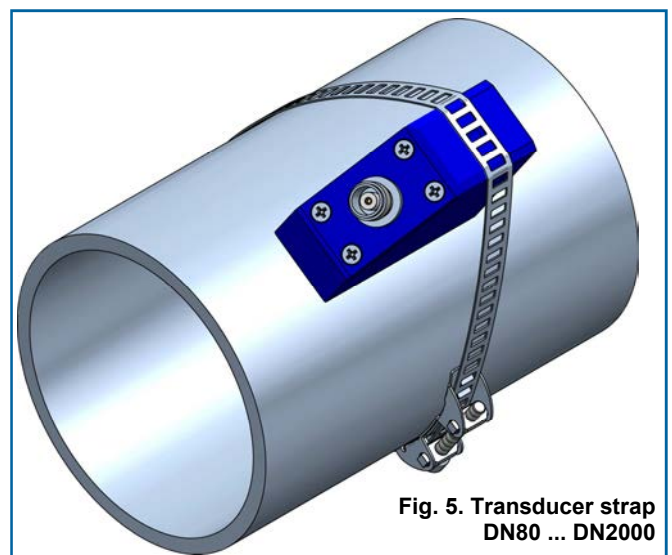

Fig. 5. Transducer strap DN80 ... DN2000

Dimensions

Fig. 6. Transducers

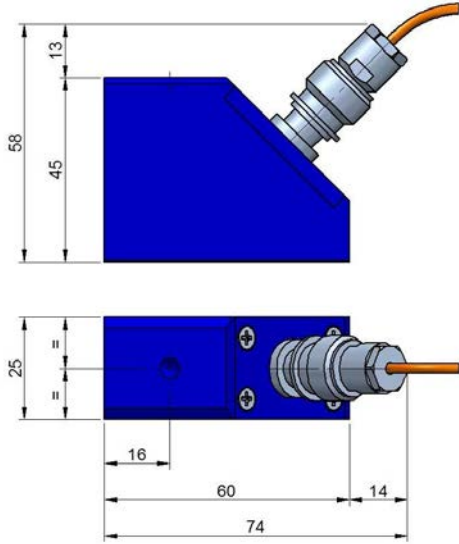

Fig. 7. Converter CU100

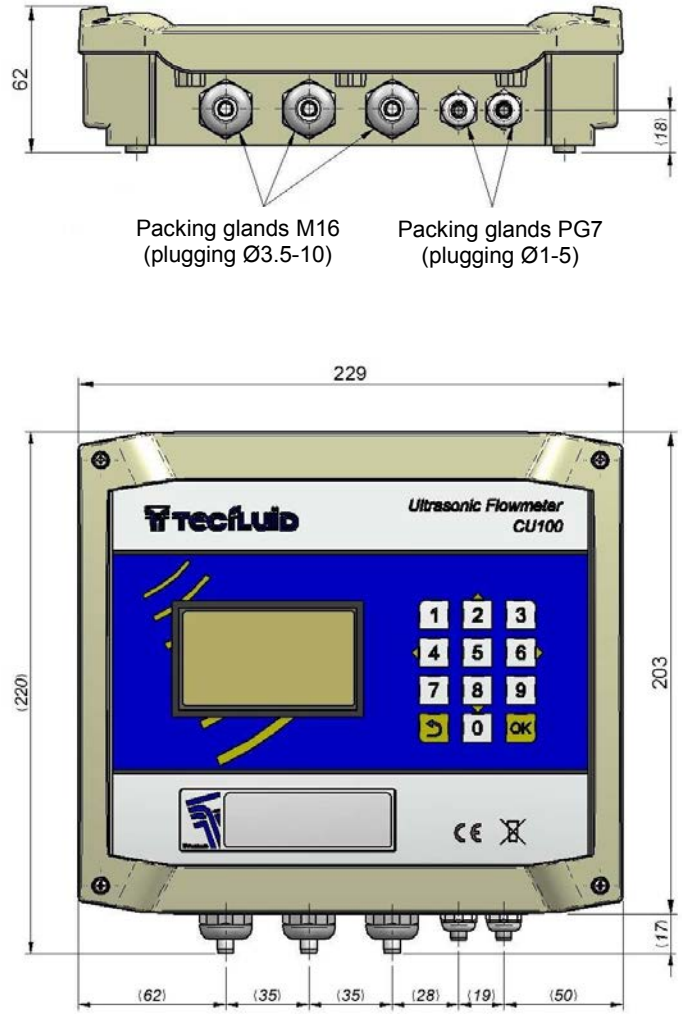
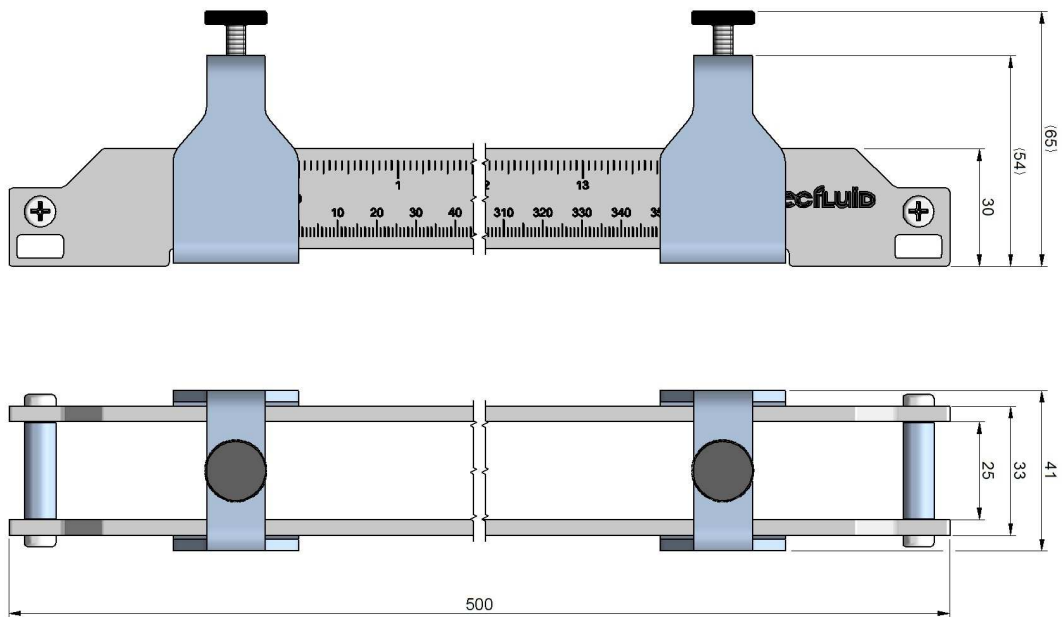
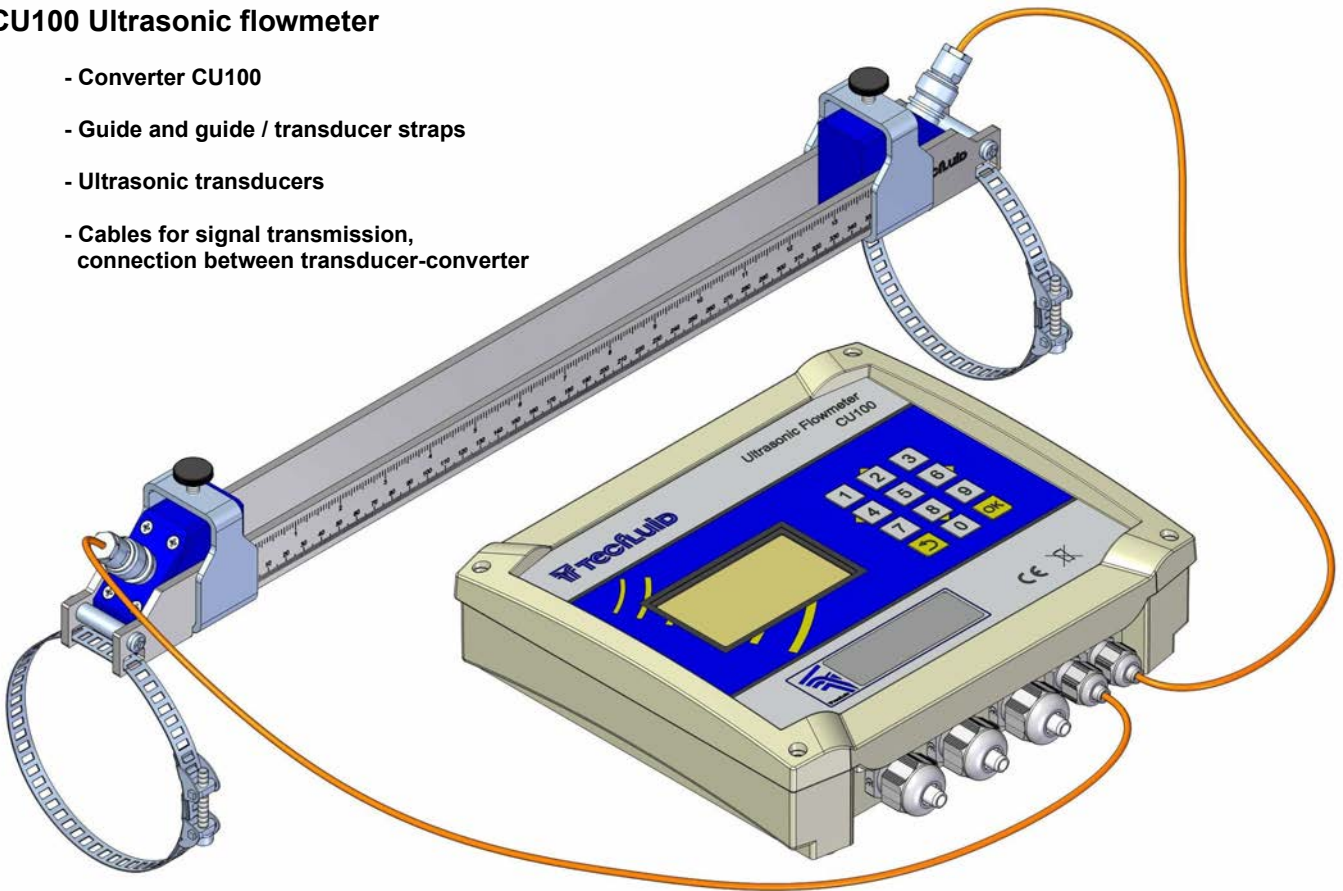

Fig. 8. Guide (DN80 ... DN350)



CU100 Ultrasonic flowmeter

- Converter CU100
- Guide and guide / transducer straps
- Ultrasonic transducers
- Cables for signal transmission, connection between transducer-converter



Programming by means of software

The flowmeter model CU100 can be fully programmed by means of a PC and the software Winsmeter CU.

This software is available for download at www.tecfluid.com.

The connection between PC and converter is easily done by means of a USB cable (not supplied).

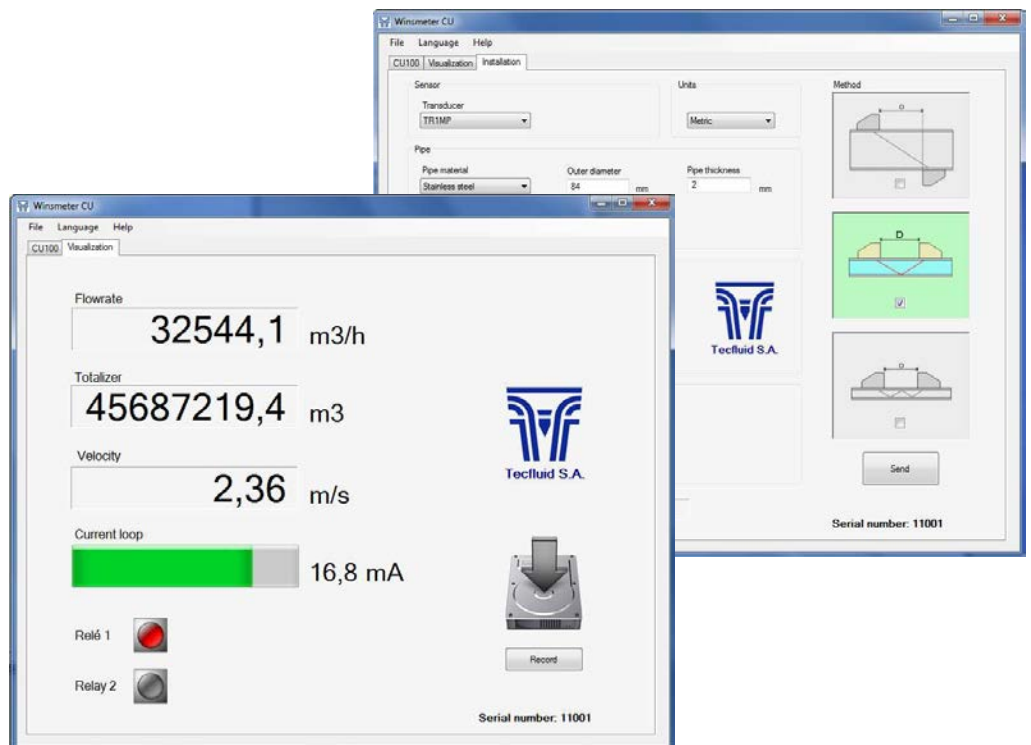



www.adinco.nl

Adinco bv

P.O.Box 90
4190 CB Geldermalsen
Netherlands

Tel. +31 (0) 345 59 60 00
Fax +31 (0) 345 59 60 01

E-mail: info@adinco.nl
Internet: www.adinco.nl