

# AIRPAX®

## JPBD and LPBD Series Protected Battery Disconnects



Telecommunication networks are highly reliable, with interruptions being predominately uncommon. To further reduce the unlikely event of an interruption, battery systems provide the critical backup power to keep these networks online. These

battery backup systems also present a potential hazard to firefighters, emergency and maintenance personnel, making the need to provide a remote or manual disconnect function more critical.

Two versions of the Airpax Protected Battery Disconnect provide highly effective and versatile solutions to address the issues associated with battery system applications. The JPBD and the LPBD series of Airpax Protected Battery Disconnects feature engineering and design innovations optimizing safety and operational requirements for a wide range of applications.

# JPBD Series Protected Battery Breaker Disconnects

Disconnecting batteries in the event of an emergency or for maintenance has just become much easier with Airpax Protected Battery Disconnects (PBD). A key component of the Airpax disconnect product is the JTEP/JTMP circuit breaker packaged in a completely front accessible enclosure. The JTEP/JTMP is UL489A Listed for use in communications equipment.

In addition to overcurrent protection and switching capability, applying a voltage signal to the optional remote trip circuit allows batteries to be disconnected from a remote location. Optional alarm and meter shunt functions can also be provided, eliminating the need to design these functions in separately.

- Disconnect and overcurrent protection
- Manual and remote disconnect capability
- Completely front accessible
- 24-160VDC operation
- Wall, rack or battery stand mounting
- LED indication of power on, off and/or tripped condition
- Standard ratings of 200, 600, 800, 1000 and 1200 amps
- Optional alarm circuit
- Optional meter shunt

## Ratings

Current Rating	Voltage	Interrupt Capacity
100 - 1200 amps	65 VDC	50,000 amps
100 - 800 amps	160 VDC	10,000 amps

### Application

Manually or remotely disconnect batteries in communications networks.

### Voltage

While primarily used in +24 and -48VDC circuits, Airpax disconnects will operate at any voltage up to 65VDC. (For higher voltages please consult the factory.)

### Terminations

Standard bus plates are configured for two hole telecom lugs. Consult factory for various bus plate configurations.

### Mounting

Airpax disconnects can be wall mounted or mounted on a battery stand. A rack mount version is also available.

### Operating Ambient

-40° to +60°C.

### Optional Alarm

An optional alarm circuit indicates power on, power off and/or tripped condition. The alarm feature can easily be accessed via a small terminal block at the top of the unit.

### Optional LED Indication

Optional LEDs on the front of the unit can visually indicate power on, power off, and/or tripped condition.

### Optional Meter Shunt

An optional 25mv at rated current, non-isolated meter shunt is available. Limited to current ratings of 800 amps max.

### Optional Remote Trip Capability

Airpax battery disconnects can be activated from a remote location allowing a safe means of disconnecting batteries in the event of a fire or other types of emergencies. A terminal block at the top of the unit provides convenient termination points. It is recommended that a two amp switch be used to activate the remote trip feature.

 Listed under  
ULFileE220375



600 Amp PBD

Wall & Frame Mount  
100 - 800 Amp

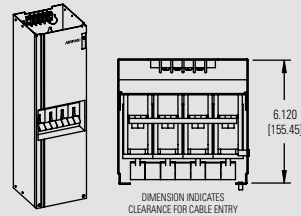

WITHOUT CABLE MANAGEMENT

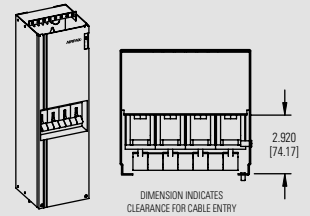

WITH CABLE MANAGEMENT

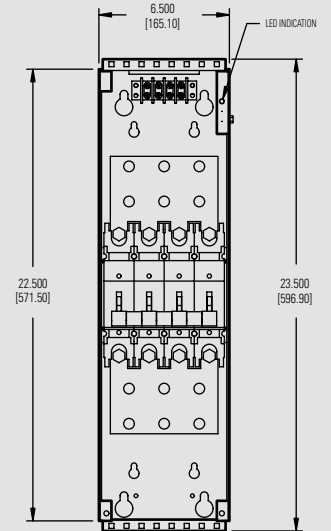
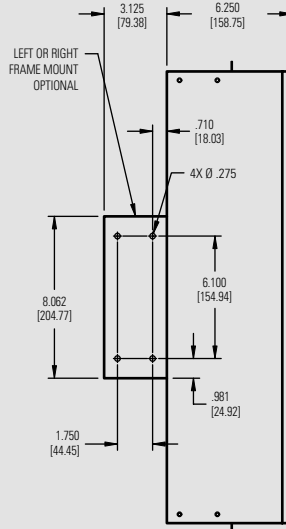
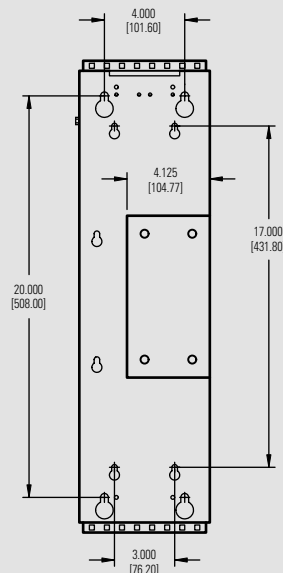

Note: Cover omitted from orthographic views for clarity.



600 Amp PBD

Wall Mount  
1000 - 1200 Amp

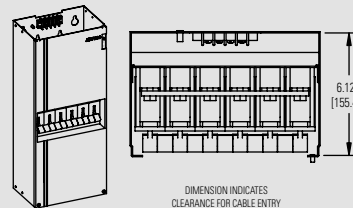

WITHOUT CABLE MANAGEMENT

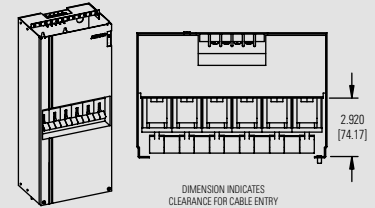

WITH CABLE MANAGEMENT

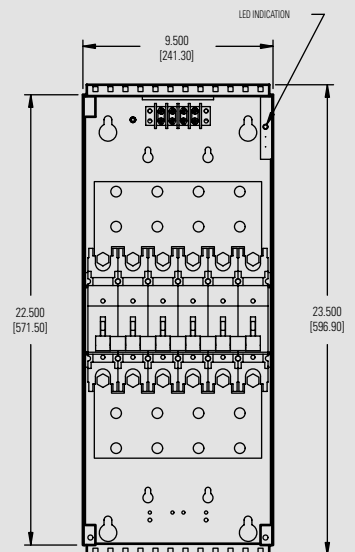
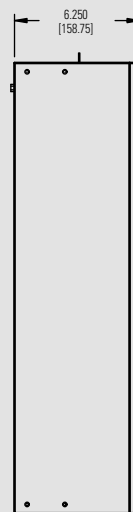
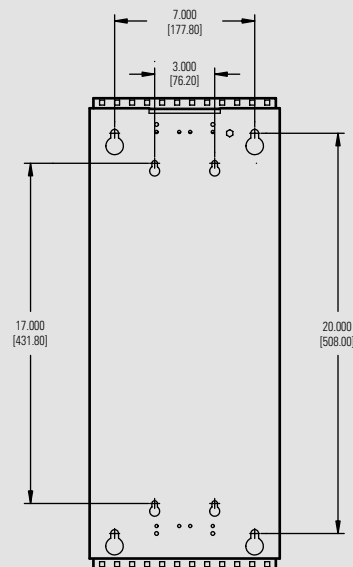

Note: Cover omitted from orthographic views for clarity.

Note: All dimensions shown in inches.  
Tolerance is  $\pm .015$  unless noted.

# Rack Mount 100 - 600 Amp



Rating	Number of Poles	Dim. "A"
100 - 600 amps	3	5.255 [133.48]

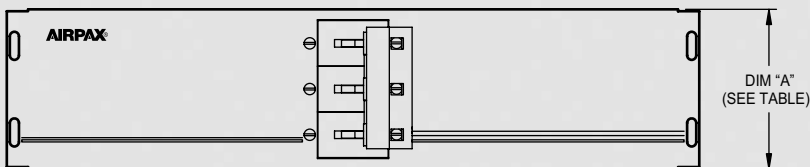
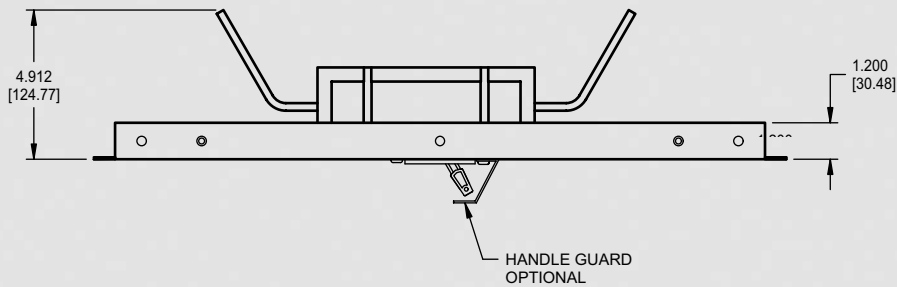
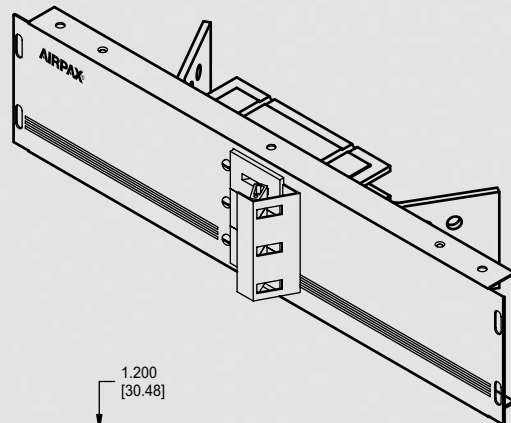

Note: All dimensions shown in inches. Tolerance is  $\pm .015$  unless noted.

Wall and Frame Mount Bus Configuration, Through Hole Connections

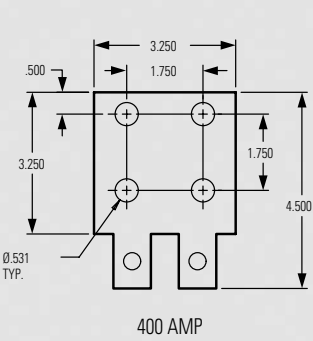

Figure 1

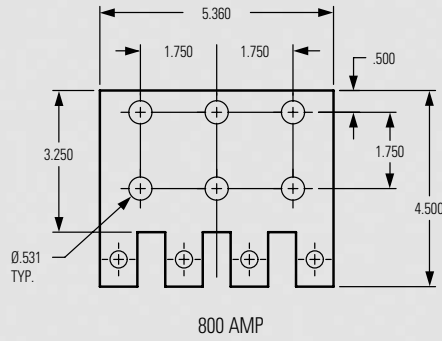

Figure 3

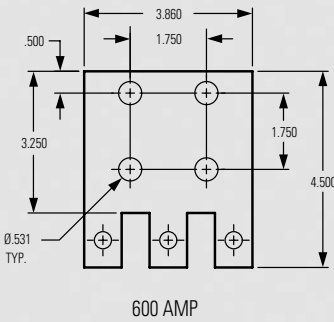

Figure 2

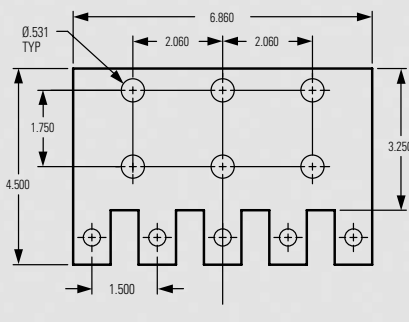

Figure 4

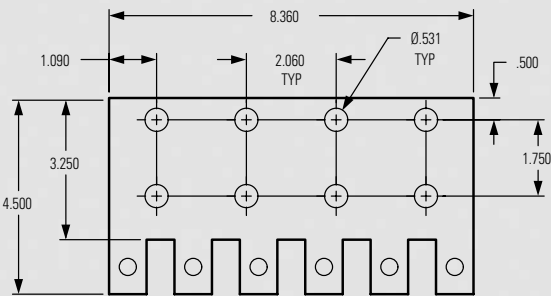
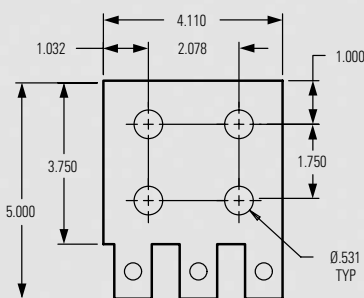
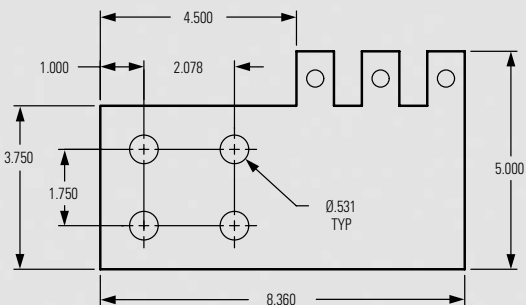

Figure 5

600 Amp Bus Bar for Top/Bottom Cable Connection



Amperage	Max. Lug Size	Max. Lug Number
1200 amps	800 MCM	4 max.
1000 amps	800 MCM	3 max.
800 amps	777 MCM	3 max.
600 amps	777 MCM	2 max.
400 amps	777 MCM	2 max.

Notes:

1. This specification covers Airpax battery disconnect bus bars from 400 amps to 1200 amps. Two through six pole construction.
2. Finish: .001" copper undercoat followed by a .00005"-.0001 tin plating with brighteners added. Reference ASTM B-545-92 regarding tin plating and solderability requirements.
3. Min./Max. Torque Requirement: 1/2 - 13 UNC...460 - 555 inch pounds.
4. Special bus plate hardware available. Consult factory.

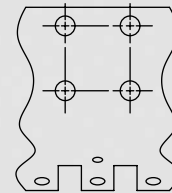

CONNECTION HOLE PATTERNS FOR RACK MOUNT ARE THE SAME AS 600 AND 1200 AMP WALL AND FRAME MOUNT VERSIONS

Rack Mount Through-hole connections

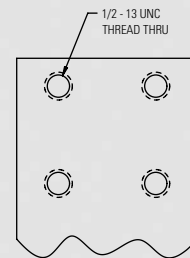

Threaded connection

Note: All dimensions shown in inches. Tolerance is ± .015 unless noted.

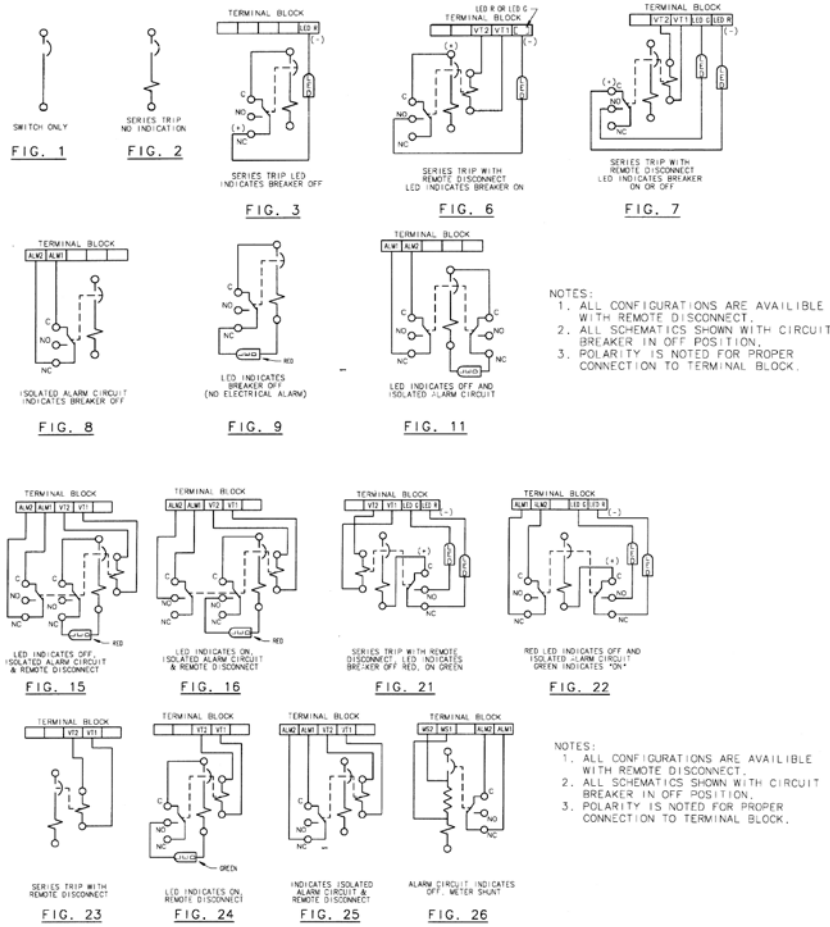

JPBD Series Decision Table

**1 First Decision**

Type

JTEPBD	Series Trip
JTMPBD	Mid-Trip

**2 Second Decision**

Aux. Switch

0	Switch only
1	Series Trip
2	REC4 - electrical/mechanical alarm

Dual aux. switches available (consult factory).

**4 Fourth Decision**

System Voltage

1	24 Volts DC
2	-48 Volts DC

**6 Sixth Decision**

LED Indication \*

0	No indication
1	Red indicating disconnected only (off)
2	Green indicating connected only (on)
3	Red (off), green (on) indication
6	Red indicating (on)

\* Requires polarity sensitive wiring assembly

**3 Third Decision**

Current Rating	Poles
A	100 amps
B	200 amps
C	250 amps
D	400 amps
E	600 amps
F	800 amps
G	1000 amps
H	1200 amps
J	350 amps

Refer to Airpax specification AM-374 for detailed circuit breaker information.

**5 Fifth Decision**

Mounting

W	Wall mount
WT	Wall mount top load only, 600A max.
WB	Wall mount bottom load only, 600A max.
FR*	Frame mount (right), 800A max.
FL*	Frame mount (left), 800A max.
R1	19 inch rack mount
R2	23 inch rack mount

\* As viewed from the front of the unit. See frame detail

**7 Seventh Decision**

Bus Bar Code

A	Thru hole connection
B	Threaded connection

Refer to Bus Bar Specifications on page 235.

**8 Eighth Decision (Optional)**

Remote Disconnect Voltage

0	No remote
1	24 VDC
2	48VDC
3	120VAC
4	240 VAC

**9 Ninth Decision (Optional)**

Options

0	No Options
G	Handle guard (rack mount only)

Example: JTEPBD - 0 - D - 1 - W - 1 - A - 2 - M

JPBD and LPBD Series

## LPBD Series Protected Battery Breaker Disconnects

Disconnecting batteries in the event of an emergency or for maintenance has just become much easier with the Airpax LPBD battery disconnect. Maximum ratings of 200 amps @ +24 or -48VDC make the LPBD ideal for outside plant, cell site, central office and co-location applications. The LPBD is available in wall mount, rack mount, custom and NEMA enclosure configurations in package sizes that require minimal space. In addition to the disconnect function the LPBD also provides over current protection and provides a fault interrupt rating of 50,000 amps.

The LPBD can be supplied with an optional remote disconnect feature allowing batteries to be disconnected with an emergency shut down switch at the service entrance of a site or from a remote monitoring center. This key feature helps address increasingly stringent requirements of local Fire Marshall's and pending NEC requirements.

In addition to remote disconnect capability the LPBD can also be configured to remotely reconnect battery circuits.



LPBD Inside Wall,  
Mount

- Disconnect and overcurrent protection
- Manual and remote disconnect and reconnect capability
- Completely front accessible
- +24 and -48VDC operation
- Wall, rack or battery stand mounting
- Optional NEMA enclosure
- LED indication of power on, off and/or tripped condition
- Standard ratings of 50, 100, 125, 150 and 200 amps
- Optional alarm circuit
- Standard Bellcore Lock

## Ratings

Current Rating	Voltage	Interrupt Capacity
50 - 100 amps	80 VDC max.	50,000 amps
125 - 200 amps	65 VDC max.	50,000 amps

### Application

Manually or remotely disconnect batteries in communications networks. Remote reconnect. Consult factory.

### Voltage

While primarily used in +24 and -48VDC circuits, Airpax disconnects will operate at any voltage up to 80VDC.

### Terminations

Consult factory for various bus plate options. Bus plates are configured for two hole telecom type lugs.

### Mounting

Airpax disconnects can be wall mounted or mounted on a battery stand. A rack mount version is also available. Consult factory for additional information.

### Operating Ambient

-40 to +60°C.

### Optional Alarm

An optional alarm circuit indicates power on, power off or tripped condition. The alarm feature can easily be accessed via a small terminal block within the unit.

### Optional LED Indication

Optional LEDs on the front of the unit can visually indicate power on, power off, and/or tripped condition.

### Optional Remote Trip Capability

Airpax battery disconnects can be activated from a remote location allowing a safe means of disconnecting batteries in the event of a fire or other types of emergencies. A terminal block is provided for convenient termination.

### Remote Reset Capability

Battery circuits can be reconnected remotely by applying a voltage signal to the optional remote actuator. A terminal block is provided for convenient termination.

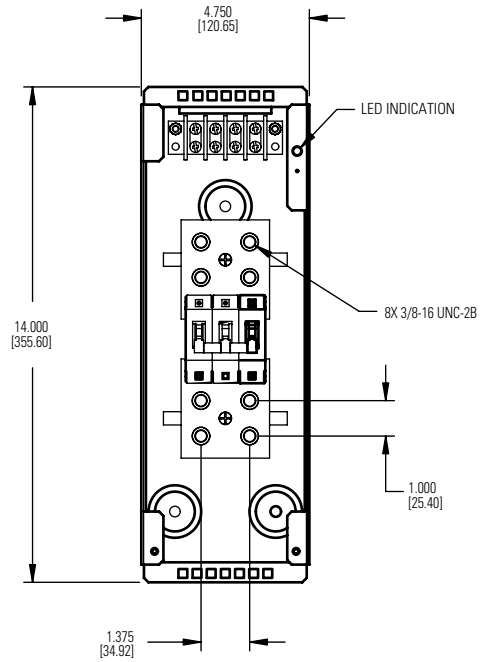
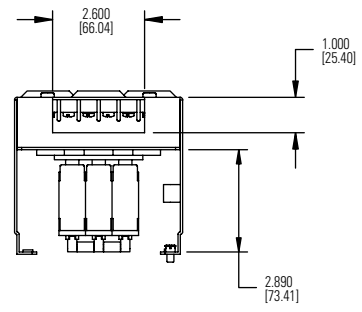

LPBD Inside Wall Mount

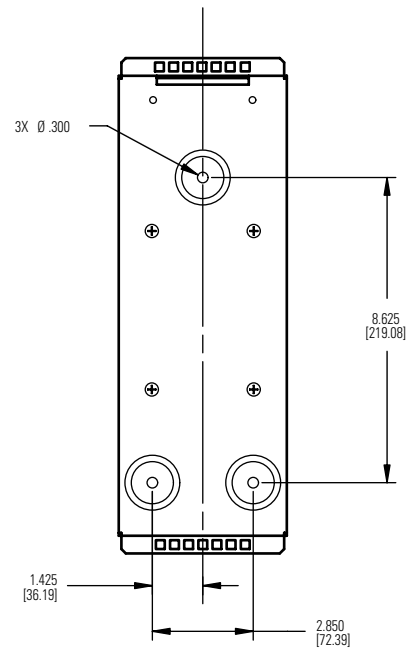
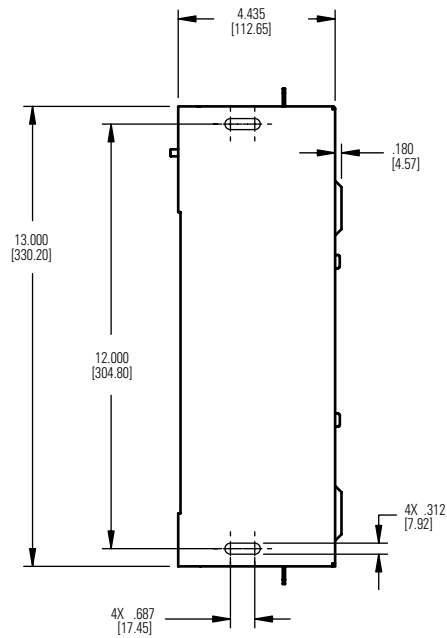
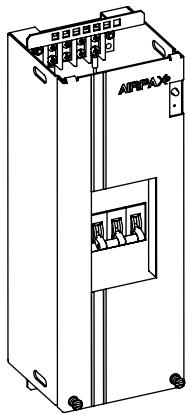

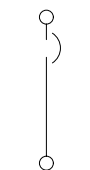

SWITCH ONLY

FIG. 1



SERIES TRIP  
NO INDICATION

FIG. 2

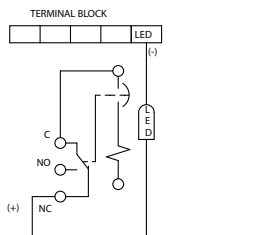

SERIES TRIP LED  
INDICATES BREAKER OFF

FIG. 3

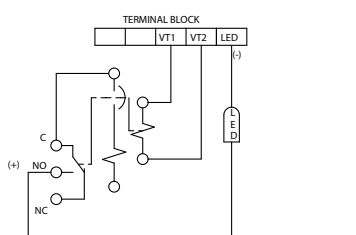

SERIES TRIP WITH REMOTE DISCONNECT  
LED INDICATES BREAKER ON

FIG. 4

Notes:

1. All configurations are available with remote disconnect.
2. All schematics shown with circuit breaker in off position.

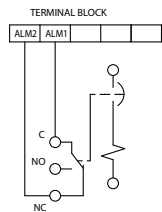
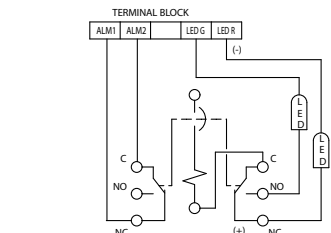
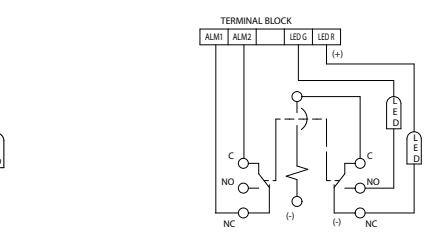

FIG. 5



ISOLATED ALARM CIRCUIT  
INDICATES BREAKER OFF

FIG. 6



SERIES TRIP WITH ALARM CIRCUIT LED  
INDICATES BREAKER RED "OFF", GREEN "ON"

FIG. 7

LPBD Series Specifications

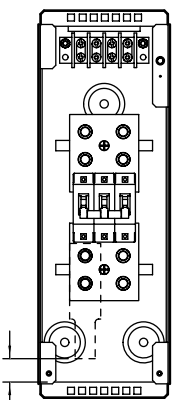

.500 MINIMUM CLEARANCE BETWEEN LUG AND HOUSING (BOTH ENDS)

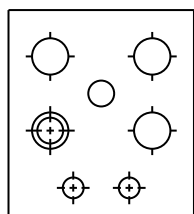

Two pole bus bar.

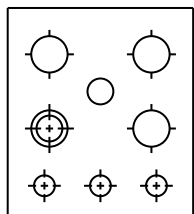

Three pole bus bar.

Recommended Lugs for LPBD (indoor)

Wire Size	Part No.	MFG
250 MCM	256-30695-1245P	Thomas & Betts
250 MCM	CL-250-2-3/8	Southport Ind.
250 MCM	CLL-25-20-3/8	Southport Ind.
250 MCM	GL250N-38	Nsi Industries
250 MCM	BLU-025D3	Penn Union
250 MCM	YA29L-2TC38	Burndy

Notes:

1. Bus Bar Finish: Tin over copper undercoat
2. Torque value for bus bar connections: 225-270 inch pounds.

LPBD Series Decision Table

